



Client _____ Quantity _____
Project _____ Position _____

FUN 700

Model: F70/40IND/A

Cod: MP01132123001

Technical data

Modularity:	On open cabinet
Dimension (mm):	400x700x850
Total electric power (kW):	7
Electric power (V):	380-415
Ampere (A):	11
Phases:	3N
Cable section (mmq):	5G2,5
Frequency (Hz):	50-60
Net volume (m3):	0,238
Packing dimensions (mm):	477x776x1147
Gross weight (kg):	55
Gross volume (m3):	0,425

Features

Working top:	Made of AISI 304 stainless steel with a thickness of 10/10 mm
Knobs:	Knobs are made from a sturdy heat-resistant polymer blend and are equipped with liquid anti-leakage washer

Technical draw

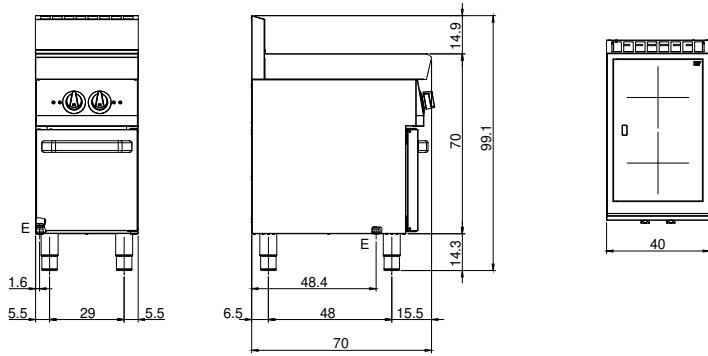

E: Electric power